

TYPE SIN 006

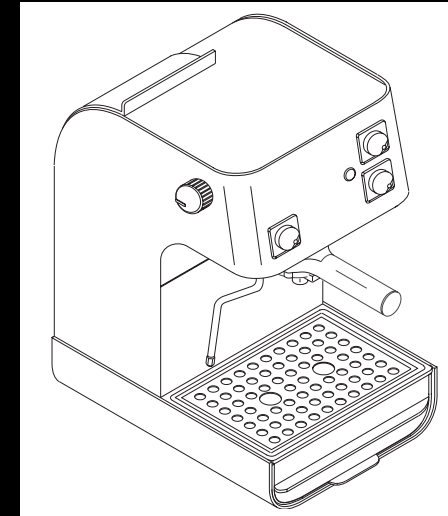

OPERATING INSTRUCTIONS

FOR YOUR SAFETY CAREFULLY READ THE OPERATING INSTRUCTIONS.

COD. 1.6.591.21.00 REV. 02 DEL. 13/11/00

FOR HOUSEHOLD USE ONLY



We congratulate for having bought this top-quality espresso machine and many thanks you for your confidence in our products.
Before operating the machine, we recommend to read the following instructions thoroughly which explain how to use, clean and maintain the machine.

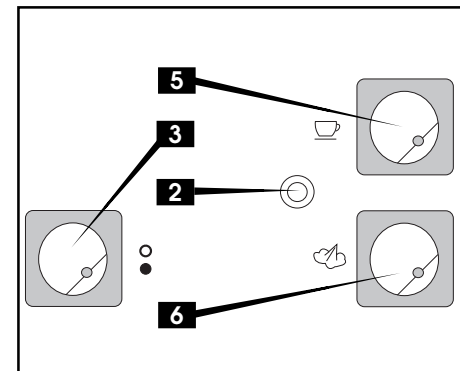
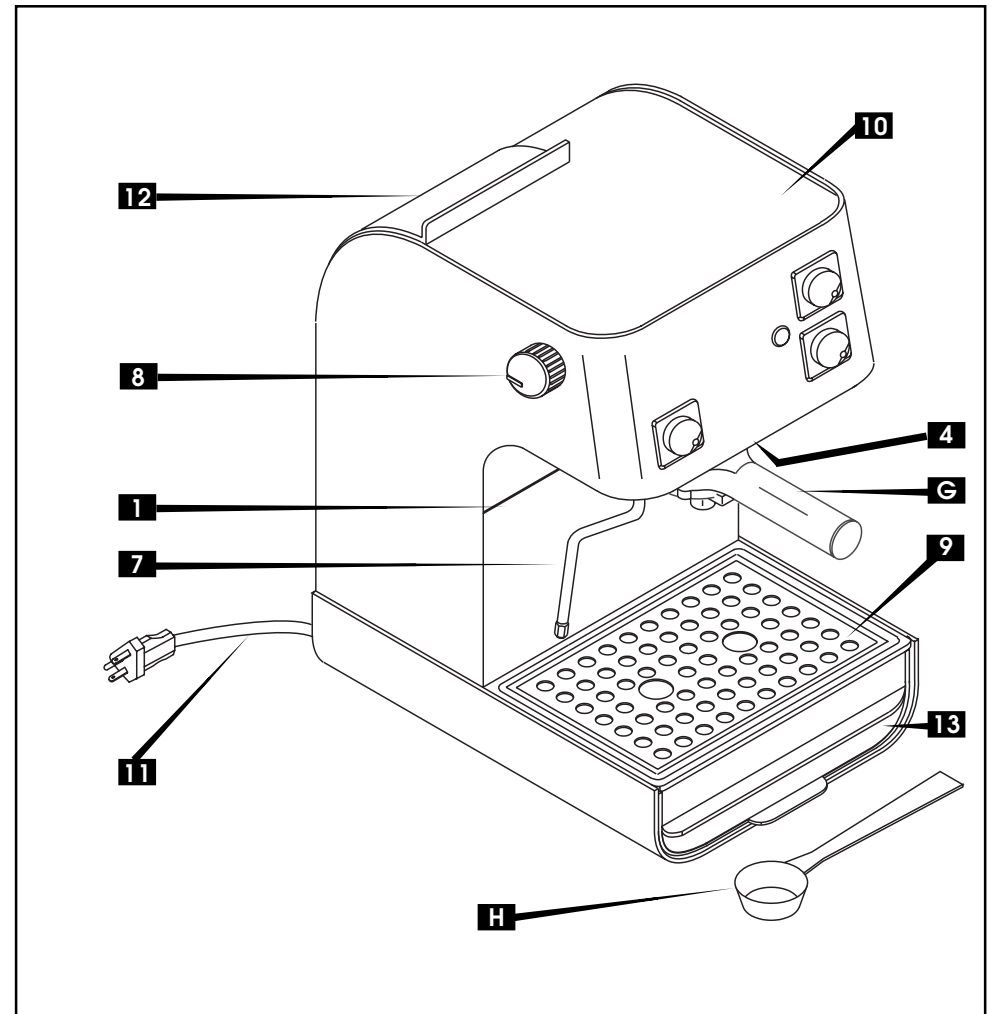

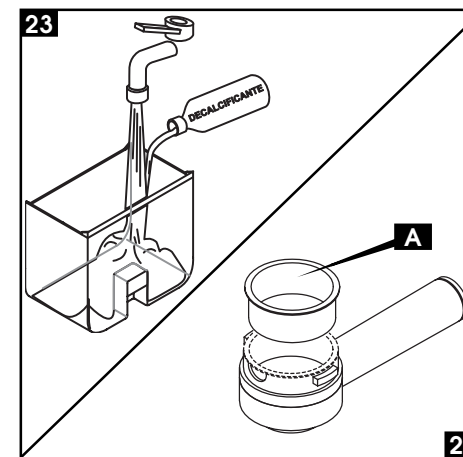
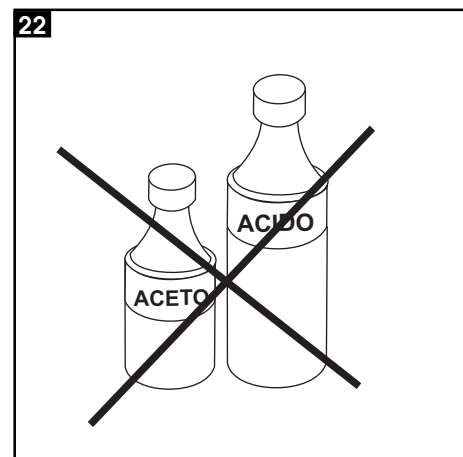
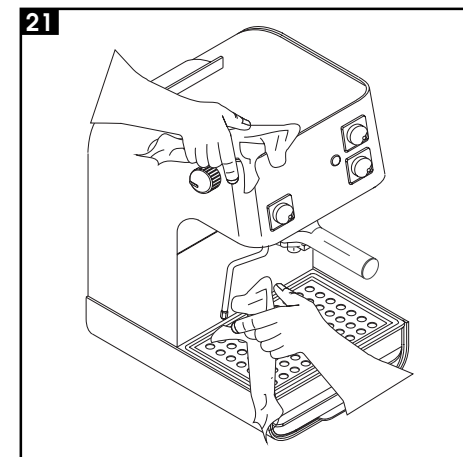
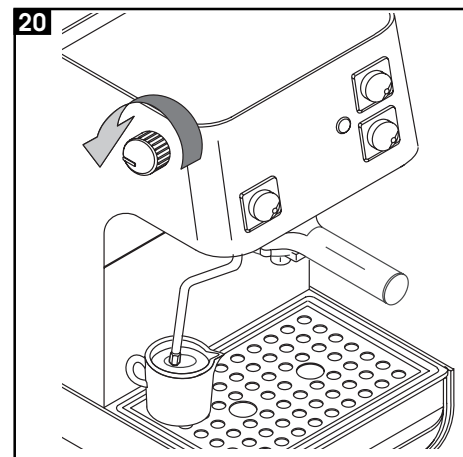
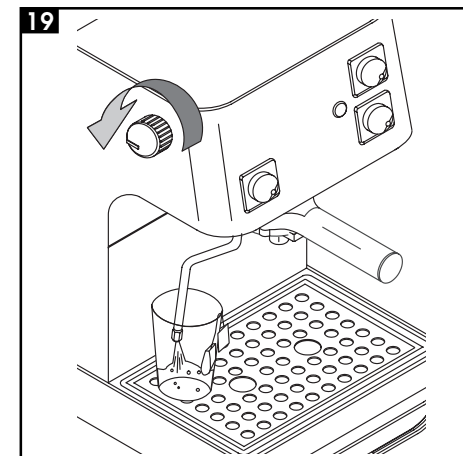
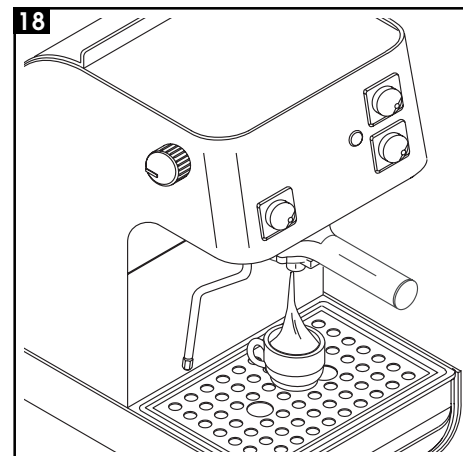
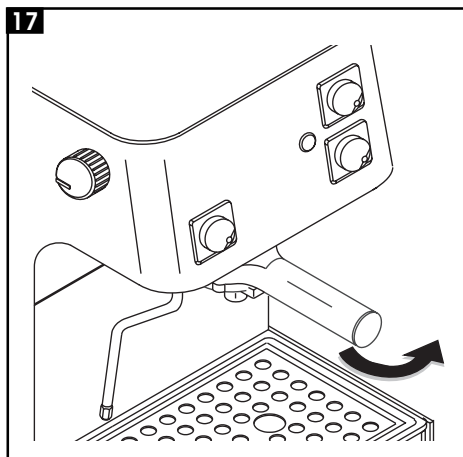
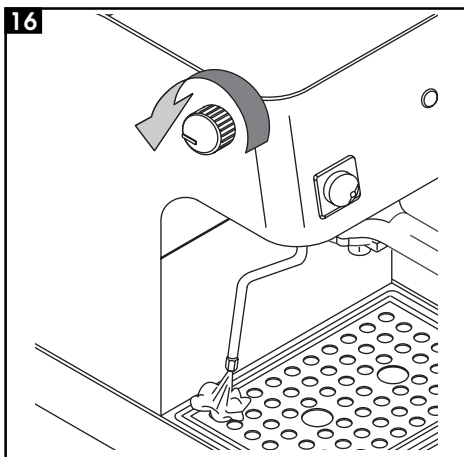
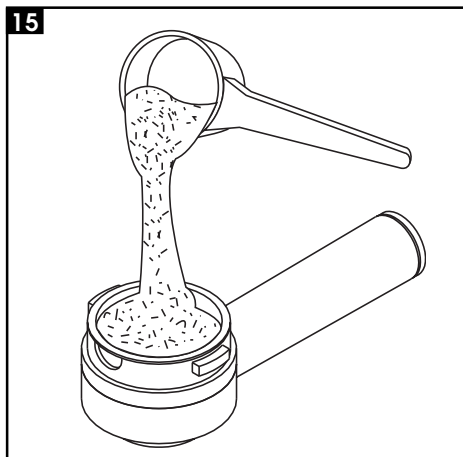
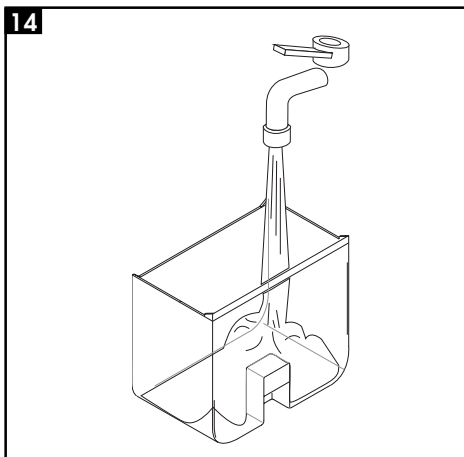
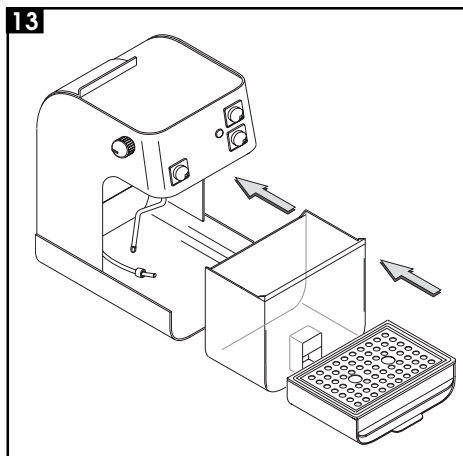
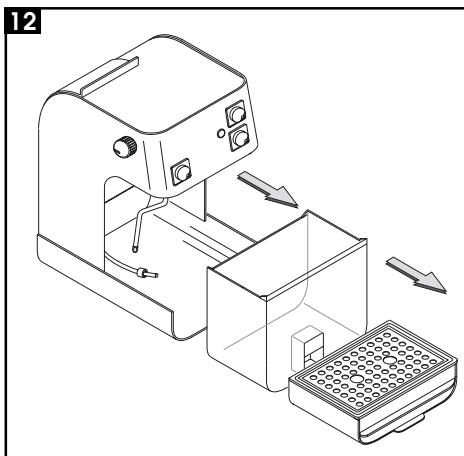

La macchina per caffè è indicata per preparare 1 o 2 tazze di caffè espresso ed è dotata di un tubo orientabile per l'erogazione del vapore e dell'acqua calda. I comandi sulla parte anteriore dell'apparecchio sono contrassegnati con i simboli di facile interpretazione. Il corpo della macchina dall'elegante design è stato progettato per uso domestico e non è indicato per un funzionamento continuo di tipo professionale.



Attenzione: Non si assumono responsabilità per eventuali danni in caso di:

- Impiego errato e non conforme agli scopi previsti;
- Riparazioni non eseguite presso centri di riparazione autorizzati;
- Impiego di pezzi di ricambio e accessori non originali.

In questi casi viene a mancare la garanzia.

This espresso machine can brew one cup of espresso or two cups simultaneously and comes equipped with a moveable steam/hot water arm. Controls on the front of the machine are easily recognizable by their corresponding icons. This elegantly designed espresso machine has been manufactured for household use only and should not be used in commercial operations. Before using the machine, thoroughly and carefully read the following instructions and always observe the safety precautions contained in this manual. Do not use the machine prior to reading and understanding the instructions in this manual!



Attention: The Manufacturer declines any responsibility for damages resulting from, but not limited to:

- Improper use of the machine;
- Unauthorized repairs or repairs carried out by unauthorized personnel;
- Use of non genuine spare parts and accessories.

The abovementioned cases void the warranty.

La machine à café est toute indiquée pour préparer 1 ou 2 tasses à café espresso. Elle est dotée d'une buse flexible pour la sortie eau chaude / vapeur.

Les commandes sur la partie antérieure de l'appareil sont marquées avec des symboles faciles à interpréter. Le corps de la machine, au design élégant, a été conçu pour un usage domestique et non pour un fonctionnement en continu de type professionnel.



Attention: Nous n'assumons pas de responsabilité pour d'éventuels dommages en cas de :

- Utilisation erronée et non conforme aux buts prévus ;
- Réparations non exécutées auprès de Centres de Réparation agréés ;
- Emploi de pièces détachées et d'accessoires non d'origine.

Dans ces cas la garantie ne fonction-ne pas.

Verehrte Kundin, verehrter Kunde mit dieser vollautomatischen Kaffeemaschine kann Espresso-Kaffee, Schümlikaffee aus Bohnen oder aus gemahlenem Kaffee zubereitet werden. Wie bei allen elektrischen Geräten ist auch bei dieser Kaffeemaschine zur Vermeidung von Verletzungen, Brand- oder Geräteschaden besondere Sorgfalt nötig. Bitte lesen Sie die vorliegende Bedienungsanleitung vor Inbetriebnahme der Kaffeemaschine und beachten Sie die Sicherheitshinweise. Personen, die mit der Bedienungsanleitung nicht vertraut sind, dürfen die Kaffeemaschine nicht benutzen.



Vorsicht: Für folgende Fälle erlischt jeglicher Garantieanspruch:

- Schäden, die durch Verkalkung, Nichtbeachtung der Bedienungsanleitung, natürliche Abnutzung, Verschmutzung, Gewaltanwendung oder übermäßiger Beanspruchung entstanden sind.
- Reparaturen, die nicht von autorisierten Fachleuten durchgeführt wurden.

Nichtverwendung von Originalteilen und Hilfsmitteln.

Do not discard this manual. Keep it for future reference in an easily accessible place near the machine. If the machine should change hands, make sure this manual accompanies the machine.

Description of symbols



The warning triangle shows all important safety indications to ensure the user's safety while operating the machine. Failure to observe the given safety instructions may result in serious injuries.

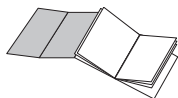

The inside first page of the cover of this manual shows figures relevant to the text. Keep it open for reference while reading the instructions.

For further information or questions concerning specific situations or problems, please contact your local dealer or an authorized service center.

B

Reference to figures, parts of the machine and control components are given by numbers or letters, as exemplified by "B" above.

Table of Contents

	page		page
Technical data	21	Choosing the quality of the coffee	25
Safety precautions	23	Dispensing hot water	26
Controls and machine parts	24	Dispensing steam	26
Set-up precautions	24	Cleaning	26
Connection to the Power Supply	24	Descaling	26
Packaging	24	Maintenance	27
Filling water tank	24	Miscellaneous information	27
Priming the system	25	Disposal of machine	27
Brewing espresso	25	Troubleshooting	28

Voltage rating	Refer to rating plate on the machine
Power consumption	Refer to rating plate on the machine
Machine housing	Metal
Dimensions (l x h x w)	220 x 320 x 290 mm
Weight	8.5 kg
Power cord length *	1.2 m
Control panel	Frontal
Filter holder	Crema
Water tank	Removable
Power supply	Refer to rating plate on the machine
Pump pressure	13-15 bars
Boiler	Stainless steel - brass

* If the power cord is defective or damaged, please contact an authorized service center to replace it as a special tool is required. Do not attempt to use the machine if the power cord is defective or damaged.

The manufacturer reserves the right to make any technical modifications deemed necessary without prior notice.

This machine conforms to the European Directive 89/336/CEE (Legislative Decree 476 dated 04/12/92) relating to the elimination of radio frequency disturbances.

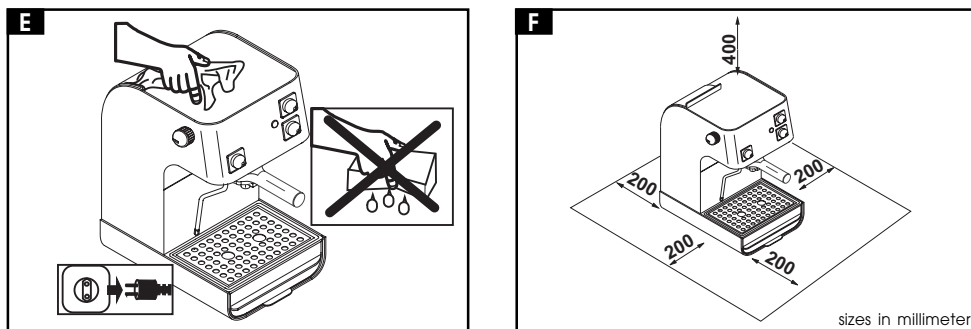
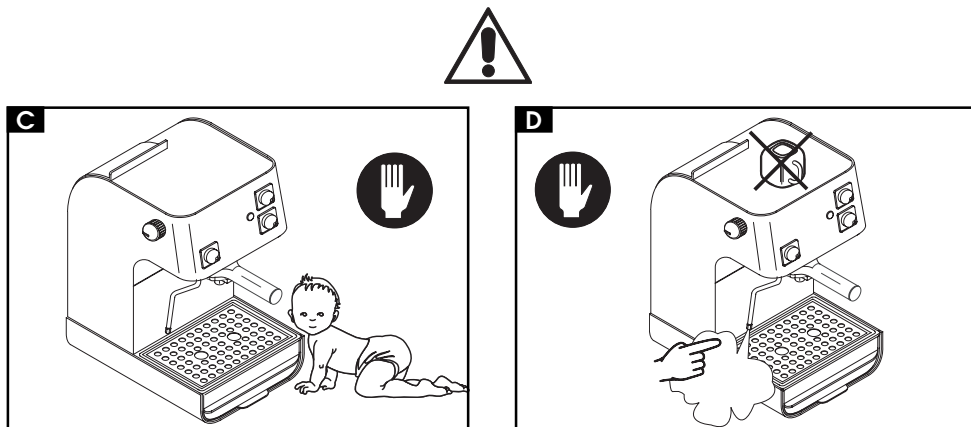
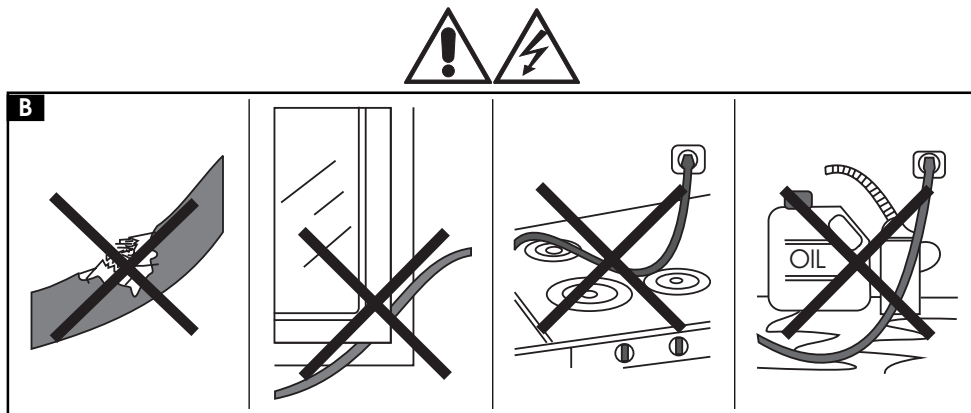
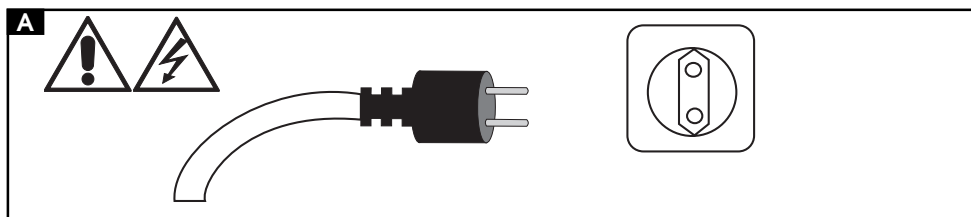

Never place electrical parts of the machine in or near water: danger of electrical shock!
Do not use the upper cover for heating cups.

Intended usage

This espresso machine has been manufactured for household use only. Do not use the machine for any other purpose or attempt to carry out technical modifications to the machine.

A Power supply

The machine should be plugged into a suitable electrical outlet only. Make sure the power of the electrical outlet corresponds to the power indicated on the rating plate of the machine.

B Power cord

If the power cord is damaged, do not attempt to use the machine. Contact your local dealer or an authorized service center for the replacement of defective power cords or plugs. Make sure the power cord is not placed near hot or sharp surfaces. Do not allow the cord to hang freely from tables or shelves and do not place the cord near oil. Do not pull on the cord to move the machine. Do not yank on the cord to unplug the machine. Never touch the power cord with wet hands.

C Keep out of the reach of small children

This espresso machine should be used only by adults who have read this instruction manual. Do not allow small children to play near or with the machine.

Location of the machine.

Place the machine on a stable, flat surface where it will not be knocked over and cause injury. Be aware that the machine makes hot water and steam: **danger of burns!** Do not place the machine outside or near hot surfaces or open flames in or

der to avoid damage to same.

D Danger of burns.

Avoid pointing steam or hot water toward the body or hands. Always handle potentially hot parts by the appropriate knobs or levers. Touch the spouts only in the areas fitted with anti-burn protective devices. Do not use the upper cover for heating cups.

E Cleaning

Before cleaning the machine, make sure that the machine is turned off and that the power cord is unplugged. Wait until the machine has cooled. Never immerse the machine in water. Do not attempt to disassemble or modify any internal components of the machine.

F Area around the machine

For the proper functioning of the machine, it is recommended:

- to place the machine on a stable, flat surface;
- to place the machine in a clean, well-lit area with an easily accessible electrical outlet.
- to allow enough space around the machine, as shown in the diagram.

Storing the machine

When the machine is not in use, unplug the power cord. Place the machine in a clean, dry, dust-free area, out of the reach of children.

Repairs / Maintenance

In the case of suspected operational problems, defects or faults, unplug the machine immediately. Never attempt to use a defective machine. **Do not attempt to repair the machine yourself.** Repairs should be carried out only by authorized service centers. The manufacturer declines any responsibility for the machine and its components and accessories for repairs made by unauthorized personnel.

Fire

Do not use the machine in an area near explosive objects. In the case of a fire, use a **carbon dioxide (CO₂) based extinguisher.** Do not use water or powder extinguishers.

Controls and machine parts - set up

- 1 Water tank
- 2 Green "ready" light
- 3 Main switch
- 4 Filter holder mounting
- 5 Coffee button
- 6 Steam button
- 7 Steam arm
- 8 Steam/hot water knob
- 9 Drip tray and grill

- 10 Cover
- 11 Power cord
- 12 Water tank funnel
- 13 Accessories box

Accessories

- G Filter holder
- H Doser

Set-up precautions

Before setting up the machine, heed the following safety precautions:

- place the machine in a safe place;
- keep children away from the machine;
- do not place the machine on hot surfaces or near open flames.

The machine is now ready to be set up.

Connection to the Power Supply

Electrical current can be dangerous, therefore the safety precautions must be rigorously respected.

 The espresso machine should be plugged into a suitable electrical outlet only.

 Make sure the power of the electrical outlet corresponds to the power indicated on the rating plate of the machine.

 Never use defective power cords or plugs. Defective parts must be replaced immediately by authorized service personnel.

Warning! If an extension cord is used, make sure that it has a minimum diameter of 1 mm² and that it has a three-pole outlet/ plug.

The voltage of the machine has been set during production at the factory. Make sure that the voltage of the power mains corresponds to that on the rating plate underneath the machine.

Make sure that the main switch (3) is in the "0" position before plugging the machine into the electrical outlet.

Packaging

The original box and packing materials have been constructed specifically to protect the machine during shipping. It is recommended to keep the box and packing materials for future shipping.

 **For your own safety and that of others, carefully heed all safety precautions indicated on pages 22 and 23.**

Filling water tank

- Remove the drip tray (9) and accessories box (13).
- 12 Remove the water tank by pulling it

our from the front of the machine.

14 Rinse the tank and fill it with fresh water. Avoid overfilling the tank.

13 Replace the water tank. Make sure the water tube hangs straight into the tank. Do not bend the tube.

- Replace the drip tray (9) and accessories box (13).

The water tank also can be filled without removing the tank.

Simply pour water into the water tank funnel (12).

 Always fill water tank only with fresh, non-sparkling water. Never fill with hot water or other liquids that could damage the tank.

 Never use the machine without water. Before turning the machine on, always make sure that the water tank is filled.

Priming the system

Before the first use of the machine, after a prolonged period without use, whenever the water tank has run completely dry, or after drawing steam the system must be primed.

16 Direct the steam arm on the drip tray. Open the steam/hot water knob (8) until a steady stream of water is dispensed. Close the knob. Insert the filter holder (G) into the brew head (4) to pre-heat the filter holder. The machine is now ready to dispense coffee.

Brewing espresso

Press the main switch (3) and wait for the green light (2) to come on. This indicates that the machine has reached the proper temperature.

15 Put 1 or 2 doses of ground coffee in

the filter, without pressing it, in order to obtain 1 or 2 espresso servings.

With the special "Crema" (G) filter holder supplied with the machine it is not necessary to change the filter for one or two servings.

17 Insert the filter holder into the brew head, turning from left to right until it locks into place.

Release the handle of the filter holder. The filter holder will automatically move slightly to the left.

This movement guarantees the perfect operation of the filter holder.

18 Place the one or two cups on the drip tray (9) below the filter holder ensuring that they are correctly positioned under the coffee spouts.

Make sure that the green "ready" light (2) is on then press the coffee button (5).

When the cups contain the desired amount of coffee, press the coffee button (5) to stop the dispensing.

Wait a few seconds, then remove the filter holder and empty the used grounds.

Cleaning hint: keep the filter of the filter holder clean by removing it and washing it with water.

Choosing the quality of the coffee

As a general rule all types of coffee on the market can be used, however, since coffee is a natural product and its flavor changes according to its origin and blend, it is advisable to try different types in order to find the one that best suits your personal tastes.

For the best results we recommend using a blend which is specifically prepared for espresso machines.

Dispensing hot water

19 Place a tea cup or glass under the steam/hot water arm (7).

Open the steam/hot water knob (8). Hot water will automatically be dispensed. To stop the flow of hot water, turn the knob (8) off.

Danger of burns!

Use caution when dispensing hot water, as small spurts of hot water may occur. The steam arm becomes hot. Do not touch it with bare hands.

Dispensing Steam

Press the steam button (6). The green "ready" light (2) will turn off until the machine reaches the correct temperature. Then the light (2) will come on again.

16 Point the steam arm (7) over the drip tray (9), open the steam/hot water knob (8) for a few seconds to release any accumulated water. After a few seconds, steam will be produced. Close the knob (8).

20 Place a cup or a frothing pitcher under the steam arm. Immerse the steam arm into the liquid and open the knob (8). Gently and slowly rotate the cup or pitcher, using up and down motions to uniformly heat the liquid. To stop the steaming function, close the knob (8) and turn off the steam button (6).

Danger of burns!

Use caution when using the steam arm. It becomes hot. Do not touch it with bare hands.

Cleaning

 Before cleaning the machine, always make sure the machine is off and that the power cord is unplugged. Allow the machine to cool.

Do not immerse the machine into water or any other fluids. Do not wash any parts of the machine in the dishwasher.

 Do not use abrasive detergents or chemical agents to clean the machine or its parts.

14 It is recommended to rinse out the water tank (1) and refill it with fresh water daily.

19 After heating milk always draw some hot water to clean the steam arm.

21 Wipe the external housing of the machine periodically with a clean, damp, non-abrasive cloth.

24 Follow the steps below to clean the filter holder:

- Remove the filter (A) from the filter holder. Place the filter in hot water and wash it gently.
- Clean the inside of the filter holder carefully to avoid damaging the pin and the sealing ring.

Descaling

- Scale normally forms while the machine is being used; descaling is necessary every 4-6 months of use or whenever you observe a decrease in water flow.

22 If you wish to descale the machine yourself, you may use any commercially available non-toxic and/or non-harmful descaling agent for coffee machines.

 **Warning! Never use vinegar as a descaling agent.**

- **23** Mix the descaling agent with water as directed on the package and pour the solution into the water container; place the water container inside the machine.

- Turn on the machine by pressing the main power switch.

- Position the steam tube over the drip tray.

- **16** Empty the entire contents from the water container at intervals (one cup at a time), by turning the steam knob counterclockwise; to cut off flow turn the knob (8) clockwise.

- During each interval, allow the descaling agent to act for about 10-15 minutes.

- **14** When all the descaling agent has been used up, take out the water container, rinse it out and fill it with fresh drinking water.

- **13** Place the container back inside the machine; empty out 2/3 of the water in the container by turning the steam knob counterclockwise; to cut off flow turn the knob clockwise.

- **16** Let the machine heat up and empty out the water remaining in the container by turning the steam knob counterclockwise; to cut off flow turn the knob clockwise.

Should you use a descaling agent other than the one recommended you are advised in any case to follow the manufacturer's directions on the package.

Maintenance

Regular maintenance of your machine by an authorized service center will prolong the life and reliability of the machine. Keep the original box and packing material for transport.

Miscellaneous information

- This instruction manual contains informa-

tion necessary for the correct and safe use and maintenance of the machine.

- The information provided and the observance of the instructions in this instruction manual provide the basis for safe use during the operation and maintenance of the machine.
- For any information not contained in this manual, or for further clarifications regarding the instructions, please contact an authorized service center, the purchase place of the machine, or the manufacturer.
- This instruction manual does not constitute part of a previous or pre-existing agreement or legal contract and its content is not affected by any such agreements or contracts. All responsibilities of the manufacturer are based on the relative sales contract which contains the complete and exclusive warranty conditions for the machine which are neither limited nor extended by this explanation.
- This instruction manual is copyrighted. It is prohibited to photocopy or translate this manual or parts thereof without prior written permission from the manufacturer.

Disposal of machine

- If the machine is to be disposed of for some reason, render it non-usable by cutting the power cord.
- Before cutting the power cord, make sure it is no longer plugged in.
- Bring your non-usable machine to an appropriate disposal center.

