

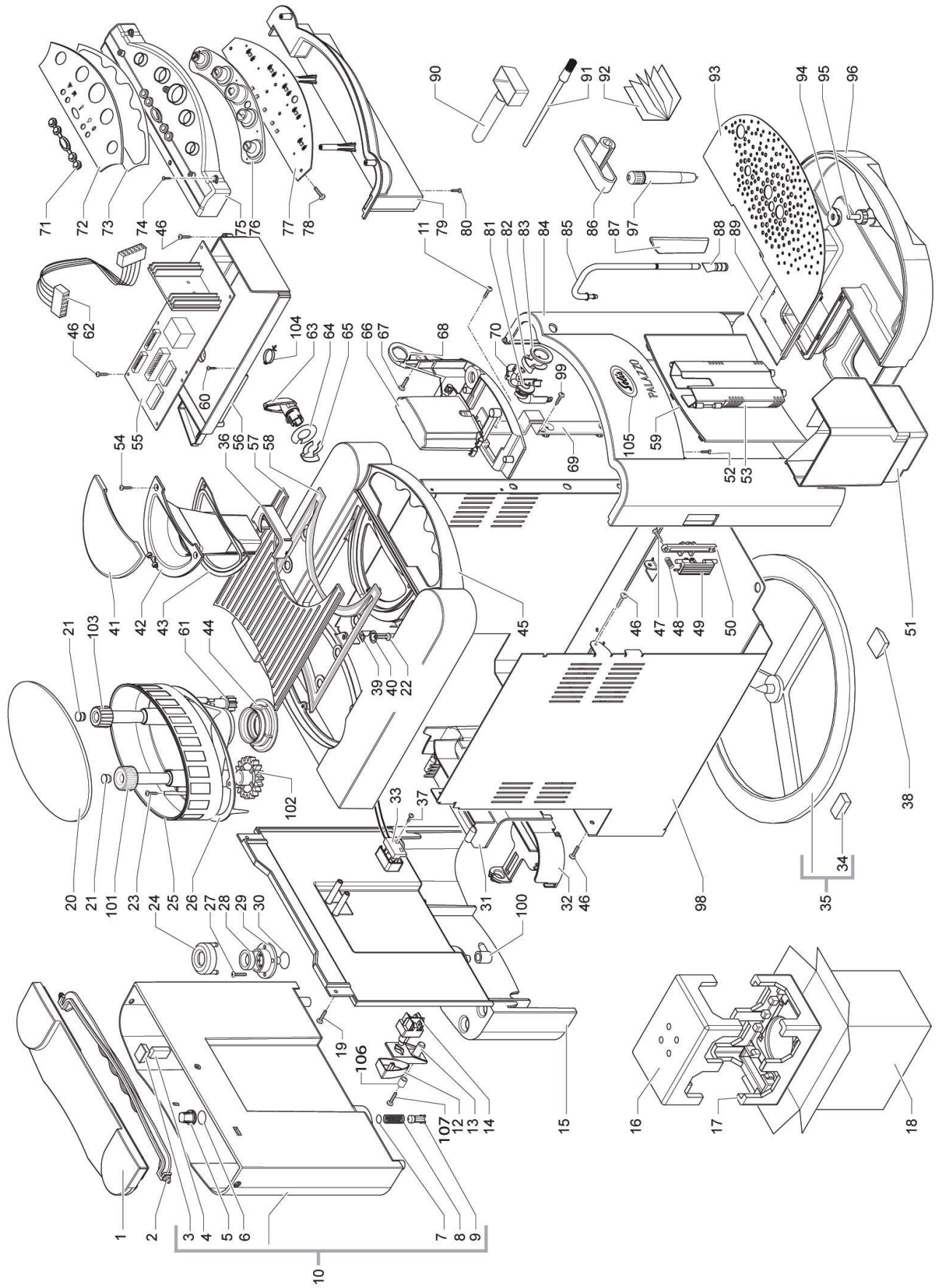

SOLIS PALAZZO

Technische Dokumentationen
Technical Documentation
Documentation technique



SOLIS LTD
 SOLIS-House
 CH-8152 Glattbrugg
 E-Mail tec@solis.ch

SOLIS Palazzo
 TD_Palazzo_Solis_26.07.05

Revision
C

Page 2 of 20
 Barbara Brechbühl
 Technik/Entwicklung

Pos	Art-Nr.	Artikelbezeichnung Deutsch	Description francais	Description english	Sp set
001	2700.00	Deckel Wassertank silber	couvercle du reser. d'eau argent	Cover water tank silver	2
001	2700.01	Deckel Wassertank d`grau RAL2802005	couvercle du reser. d'eau gris RAL2802005	Cover water tank grey RAL2802005	2
002	2700.02	Wassertankgriff schwarz	anse du reservoir noir	Handle water tank black	5
003	2400.50	Schwimmer-Deckel	couvercle du flotteur	Swimmer cover	
004	2400.51	Schwimmer	floteur	Swimmer	
005	2700.03	Wasserfilter	filtre d'eau	Suction filter	
006	2700.04	O-Ring 0019-10 EPDM	joint torique 0019-10 EPDM	O-ring 0019-10 EPDM	
007	2400.38	O-Ring Orm 0060-303 Silikon sw	or-orm 0060-30 noir	O-ring ORM 0060-303 Silicone black	
008	2700.05	Feder Wassertank	ressort p.recip. d'eau	Spring water reservoir	
009	2400.40	Ventilzapfen	bouchon de valve	Seal retainer, grey	
010	2700.06	Wassertank komplett grau	reservoir d'eau compl.	Reservoir complete	2
011	2700.07	Schraube TCB 2.9x9.5 DIN 7981	vis TCB 2.9x9.5 DIN 7981	Screw TCB 2.9x9.5 DIN 7981	
012	2700.08	Hauptschalter silber	interrupteur principal argent	Switch knob silver	2
012	2700.09	Hauptschalter d`grau RAL2802005	interrupteur princip.grisRAL2802005	Switch knob grey RAL2802005	1
013	2700.10	Schaltersupport schwarz	appui d'interrupteur noir	Switch holder black	
014	2700.11	Hauptschalter 230V	commutateur principal noir 230V	Main switch 230V	1
015	2700.12	Tanksupport silber	support du reserv. d'eau argent	Support water tank silver	1
015	2700.13	Tanksupport d`grau RAL2802005	support du res.d'eau RAL2802005	Support water tank RAL2802005	1
016	2700.14	Styropor-Einsatz oben	insert de styropor en haut	Upper Styrofoam packaging insert	
017	2700.15	Styropor-Einsatz unten	insert de styropor en bas	Lower Styrofoam packaging insert	
018	2700.16	Faltschachtel Palazzo Silver	boite pliante Palazzo Silver	Corton box Palazzo Silver	
018	2700.17	Faltschachtel Palazzo Graphite	boite pliante Palazzo Graphite	Carton box Palazzo Graphite	
018	2700.80	Verpackung Abtropfschale	coupele d'egouttage emballage	Trip tray packing	
018	2700.90	Schaumstoffabdeckung	plastique couverture	Plastic cover	
019	2700.18	Schraube TSP 2.9x16 Torx	vis TSP 2.9x16 Torx	Screw TSP 2.9x16 Torx	
020	2700.19	Deckel Bohnenbehälter silber	couv. du bac des grains argent	Cover bean container silver	2
020	2700.20	Deckel Bohnenbehälter d`grau RAL2802005	couv. du bac des grains gris RAL2802005	Cover bean container grey RAL2802005	2
021	2700.21	Verschlusskappe	couvercle	Covercup	
022	2700.22	Schraube TCB PH/SW 4x10 UNI 8112	vis TCB PH/SW 4x10 UNI 8112	Screw TCB PH/SW 4x10 UNI 8112	
023	2502.53	Schraube Tcb 3,5 x 16	vis tcb 3.5x16	Screw, TCB 3.5 x16	
024	2400.41	Kappe zu Ventil	chape de valve	Valve cap	
025	2700.23	Bohnenbehälter transparent	reserv. d. grains café transparent	Coffee bean container transparent	2
026	2700.24	Dichtung zu Bohnenbehälter	joint du bac des grains	Seal beancontainer	
027	2502.16	Schraube 3.5x9.5	vis 3.5x9.5	Screw, 3.5x9.5	
028	2701.84	Dichtung Gaco D=14	joint Gaco D=14	Seal Gaco D=14	5
029	2502.17	Dichtungsbehälter grau	porte-joint gris	Seal retainer, grey	
030	2390.64	O-Ring zu Stutzen 0080-20	o-ring p soutien 0080-20	O-ring 0080-20	
031	2700.25	Netzkabelbox	boite cable d'alimentation	Main cable box	
032	2700.26	Kabelführung	cable entrée	Cable entrance	
033	2700.27	Reedkontakt 230V	contact reed 230V	Reed contact 230V	
034	2700.28	Fuss Drehring	ped p. bague tournante	Rubber food rotating ring	
035	2700.29	Drehring grau	bague tournante gris	Rotating ring grey	2
036	2700.30	Dichtung	joint	Seal	
037	2700.31	Schraube TBC 2.9x9.5 DIN7981Inox	vis TBC 2.9x9.5 DIN 7981 Inox	Screw TBC 2.9x9.5 DIN 7981 Inox	
038	2700.32	Fuss schwarz	pied noir	Rubber food black	

SOLIS LTD SOLIS-House CH-8152 Glattbrugg E-Mail tec@solis.ch	SOLIS Palazzo TD_Palazzo_Solis_25.03.05	Revision	Page 3 of 20
		C	Barbara Brechbühl Technik/Entwicklung

Pos	Art-Nr.	Artikelbezeichnung Deutsch	Description francais	Description english	Sp set
039	2700.33	Winkel	angle	Angle	
040	2700.34	U-Scheibe	anneau	Washer	
041	2700.35	Deckel zu Pulvertrichter silber	couvercle argent	Cover silver	2
041	2700.36	Deckel zu Pulvertrichter m`grau RAL2804005	couvercle gris RAL2804005	Cover grey RAL2804005	1
042	2700.37	Trichter Kaffeepulver schwarz	cone pour le poudre de café noir	Funnel coffee powder black	2
043	2700.38	Dichtung zu Trichter	joint du cone	Seal funnel	
044	2700.39	Dichtung Bohnenbehälter	joint du bac de grains	Seal beancontainer	
045	2700.40	Gehäuse-Oberteil silber	partie sup. du boîtier argent	Top cover silver	1
045	2700.41	Gehäuse-Oberteil d`grau RAL2802005	partie sup. du boîtier gris RAL2802005	Top cover grey RAL2802005	1
046	2700.42	Schraube Panelv. TCB 3x16 DIN7505	vis Panelvit TCB 3x16 DIN 7505	Screw Panelvit TCB 3x16 DIN 7505	
047	2700.43	Schraube TCB 2.9x6.4 DIN 7981	vis TCB 2.9x6.4 DIN 7981	Screw TCB 2.9x6.4 DIN 7981	
048	2700.44	Feder zu Türauftaste	ressort p. la bouton de la porte	Spring door knob	
049	2700.45	Türtaste d`grau RAL2802005	boutton de la porte gris RAL2802005	Door knob grey RAL2802005	
049	2700.52	Türtaste silber	bouton de la porte argent	Door knob silver	
050	2700.46	Befestigungsplatte zu Türtaste	plaque de fixation pour le bouton	Fastening plate door knob	
051	2700.47	Satzbehälter schwarz	bac de marc de café noir	Waste container black	
052	2502.72	Schraube TCB 3x12	vis TCB 3x12	Screw TCB 3 x12	
053	2700.48	Kaffeeauslauf m`grau RAL2804005	ecoulement café gris RAL2804005	Coffee outlet grey RAL2804005	1
053	2700.49	Kaffeeauslauf d`grau RAL2802005	ecoulement café gris RAL2802005	Coffee outlet grey RAL2802005	1
054	2700.50	Schraube Full TSP PH 3.5x16	vis Full TSP PH 3.5x16	Screw Full TSP PH 3.5x16	
055	2700.51	Steuerprint Alu 230V	carte imprime alu d.commande 230V	Control PCP Alu 230V	2
055	2702.00	Steuerprint Inox 230V	carte imprime d.commande Inox 230V	Control PCP Inox 230V	1
056	2700.53	Support zu Steuerprint sw	support pour l'imprime	Support to cntrol PCB	
057	2700.54	Tassenablage m`grau RAL2804005	feuille p. tasses gris RAL2804005	Cup tray grey RAL2804005	
058	2700.55	Dichtung zu Tassenablage	joint	Seal	
059	2700.56	Abdeckung Tür d`grau RAL2802005	couverture gris RAL2802005	Front panel grey RAL2802005	
059	2700.57	Abdeckung Tür m`grau RAL2804005	couverture gris RAL2804005	Front panel RAL2804005	
060	2700.58	Schraube Panelv. TCB 3x10 DIN7505	vis Panelvit TCB 3x10 DIN 7505	Screw Panelvit TCB 3x10 DIN 7505	
061	2700.59	Zahnrad Mengeneinstellung	pignon réglage du café	Gear wheel coffe adjustm.	
062	2700.60	Flachbandkabel	cable plat	Flat cable	
063	2700.61	Drehknopf m`grau RAL2804005	bouton tourn. de vapeur gris RAL2804005	Rotary knob grey RAL2804005	2
064	2700.62	Distanzstück	distance	Spacer	
065	2700.63	Feder	ressort	Spring	
066	2700.64	Kaffeeauslauf Führung m`grau RAL2804005	guidage ecoulement de café gris RAL2804005	Coffee outlet guide grey RAL2804005	1
066	2700.65	Kaffeeauslauf Führung d`grau RAL2802005	guidage ecoulement de café gris RAL2802005	Coffee outlet guide grey RAL2802005	1
067	2700.66	Schraube TCB 2.9x9.5 UNI 6956 NIK	vis TCB 2.9x9.5 UNI 6956	Screw TCB 2.9x9.5 UNI 6956	
068	2700.67	Support Kaffeeauslauf	support ecoulement de café	Support coffee outlet	2
069	2700.68	Türscharnier schwarz	charniere de porte noir	Door hinge black	1
070	2700.69	Support Dampfrohr linke Seite	supporte tube de vapeur gauche	Support steam tube left side	
071	2700.70	LED Lichtleiter	LED conducteur de lumiere	LED Light line	
072	2700.71	Bedienfeld silber	champ de commande argent	Control panel silver	

SOLIS LTD SOLIS-House CH-8152 Glattbrugg E-Mail tec@solis.ch	SOLIS Palazzo TD_Palazzo_Solis_25.03.05	Revision	Page 4 of 20
		C	Barbara Brechbühl Technik/Entwicklung

Pos	Art-Nr.	Artikelbezeichnung Deutsch	Description francais	Description english	Sp set
072	2700.72	Bedienfeld d`grau RAL2802005	champ de commande gris RAL2802005	Control panel grey RAL2802005	
073	2700.73	Klebeband Bedienfeld	ruban adhesif champ de commande	Adhesive tape control panel	
074	2502.72	Schraube TCB 3x12	vis TCB 3x12	Screw TCB 3 x12	
075	2700.74	Tastatursupport d`grau RAL2802005	clavier supporte gris RAL2802005	Support keyboard grey RAL2802005	
076	2700.75	Silikon Tastatur	silicone clavier	Keyboard silikon	
077	2700.76	Bedienprint	print clavier	Print keyboard	1
078	2502.72	Schraube TCB 3x12	vis TCB 3x12	Screw TCB 3 x12	
079	2700.77	Abdeckung	couverture	Cover	
080	2700.78	Schraube Panelvit TCB 3x12 Torx	vis Panelvit TCB 3x12 Torx	Screw Panelvit TCB 3x12 Torx	
081	2700.79	Support Dampfrohr rechte Seite	supporte tube vapeur droite	Support Steam tube right side	
082	2700.63	Feder	ressort	Spring	
083	2700.81	Distanzstück Dampfrohr	distance tube de vapeur	Spacer steam tube	
084	2700.82	Türe silber Solis	porte argent Solis	Door silver Solis	1
084	2700.83	Türe d`grau Solis RAL2802005	porte gris Solis RAL2802005	Door grey Solis RAL2802005	1
085	2700.84	Dampfrohr	tube de vapeur	Steam tube	1
086	2701.85	Schlüssel zu Sieb	cle de filtre	Sieve tool	6
087	2700.85	Griff Dampfrohr m`grau RAL2804005	poignee vapeur gris RAL2804005	Handle steam tube grey RAL2804005	
088	2700.86	Dichtung Griff	joint poignee	Seal handle	
089	2700.87	Dichtung zu Abtropfschale	joint de coupelle d'egouttage	Seal drip tray	
090	2700.88	Messlöffel schwarz	cuiller de mesure noir	Measuring spoon black	2
091	0977.09	Reinigungs-Pinsel	pinceau de nettoyage	Cleaning brush	2
092	2700.89	Set Bedienungsanleitung Palazzo	mode d'emploi Palazzo	Manual Palazzo	
093	2700.96	Abtropfblech Inox	plaque d'egouttage Inox	Drip plate Inox	1
094	2700.97	Schwimmer Deckel sw	couverture du flotteur	Float cover	1
095	2700.98	Schwimmer rot	flotteur rouge	Float red	1
096	2700.99	Abtropfschale silber	coupele d'egouttage argent	Drip tray silver	1
096	2701.00	Abtropfschale d`grau RAL2802005	coupele d'egouttage gris RAL2802005	Drip tray grey RAL2802005	1
097	2701.01	Cappuccino-Dampfdüse	tube vapeur cappuccino	Cappuccino Steam Nozzle	1
098	2701.02	Gehäuse d`grau RAL2802005	caisson gris RAL2802005	Case grey RAL2802005	
098	2701.03	Gehäuse m`grau RAL2804005	caisson gris RAL2804005	Case grey RAL2804005	
099	2701.04	Schraube Panelv. TCB 3x16 DIN7505	vis Panelvit TCB 3x16 DIN 7505	Screw Panelvit TCB 3x16 DIN 7505	
100	2701.05	Gummi Raccord 90°	raccord en gomme 90°	Angeled rubber connector 90°	
101	2701.06	Regulierknopf Mahlfeinheit	bouton de regl. du mouture	Grinder adjustment knob	
102	2502.52	Zahnrad zu Mahlgradverstellung	pignon	Cog wheel	
103	2701.07	Verstellrad Mengeneinstellung	bouton de réglage du café	Knob coffee adjustment	
104	2700.91	Kabelhalter	porte-câble	Cable support	
105	2701.76	Logo Solis	logo Solis	Logo Solis	
106	2701.91	Distanzstück	distance	Spacer	
107	2701.92	Schraube 2.9x19 DIN 7981	vis 2.9x19 DIN 7981	Srew 2.9x19 DIN 7981	

SOLIS LTD SOLIS-House CH-8152 Glattbrugg E-Mail tec@solis.ch	SOLIS Palazzo TD_Palazzo_Solis_25.03.05	Revision	Page 5 of 20
		C	Barbara Brechbühl Technik/Entwicklung

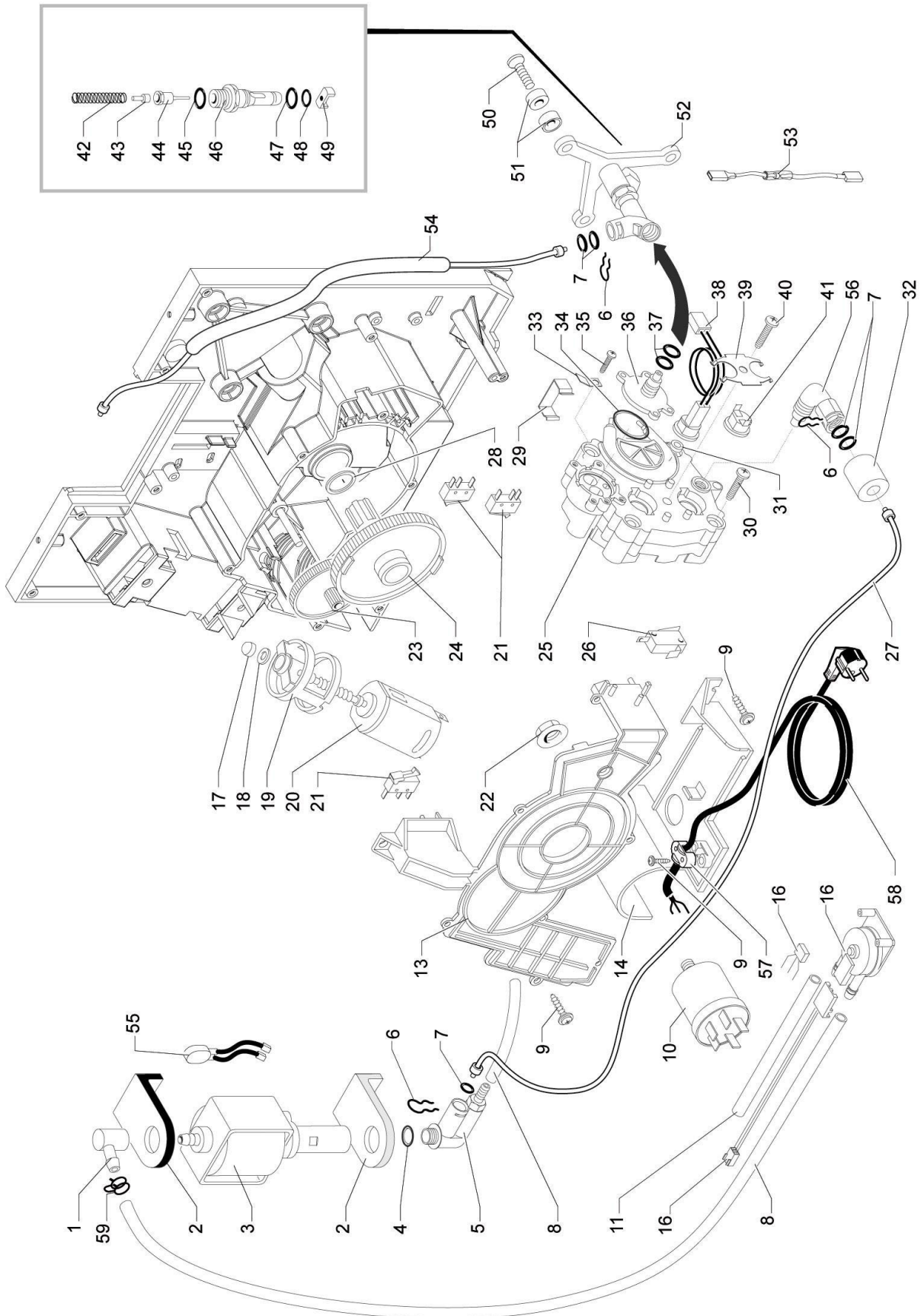

Pos	Art-Nr.	Artikelbezeichnung Deutsch	Description francais	Description english	Sp set
001	2401.22	Gummi Raccord 90°	raccord en gomme 90 degre	Angled rubber connector	
002	2503.11	Pumpenaufhängung	suspension de la pompe	Pump support	
003	2390.92	Pumpe EX5 230V	pompe ex5 230V	Pump EX5 230V	2
004	2391.23	Dichtung zu Sicherheitsventil	joint torique 2031	O-ring, 2031	10
005	2701.08	Sicherheitsventil 90°	Soupape de surete 90°	Safety valve 90°	2
006	2503.13	Klemmfeder	ressort de blocage	Spring clip	5
007	2503.14	O-Ring 2015 silikon PTFE/FDA	joint torique 2015	O-ring, 2015	30
008	2701.24	Silikon- Schlauch L=230 5x8	tuyau de silikon L=230 5x8	Silicone tube L=230 5x8	
009	2502.53	Schraube Tcb 3,5 x 16	vis tcb 3.5x16	Screw, TCB 3.5 x16	
010	2503.97	Entstörfilter	filtre anti parasite	Noise filter	1
011	2701.25	Silikon- Schlauch L=220 5x10	tuyau de silikon L=220 10x8	Silicone tube L=220 10x8	1
013	2701.10	Getriebedeckel grau	couvercle d'engrenage gris	Gear box lid grey	
014	2701.11	Flowmetersupport	support de la turbine	Support flowmeter	
016	2701.13	Flowmeter kompl.	turbine compl.	Flowmeter complete	1
017	2401.55	Lager	depot	Porous bearing for geared motor	
018	2401.54	Unterlagscheibe D 5,5	rondelle d 5,5	Bakelite washer for geared motor	
019	2401.51	Schwingungsdämpfer	etouffeur	Rubber bearing for geared motor	
020	2701.39	Getriebemotor kompl.	moteur compl.	motor kompl.	1
021	2401.58	Mikroschalter Getriebe Xch5-81	interrupteur miniature command	Micro-switch	4
022	2503.98	Mutter zu Entstörfilter	écrou pour filtre anti parasite	Nut for noise filter	
023	2701.19	Schneckenrad ZE weiss	roue helicoidale	Worm gear wheel	2
024	2701.14	Antriebsrad	roue d'entrainement	Drive wheel	2
025	2701.15	Thermoblock 230V	chauffe-eau 230V	Water heater 230V	2
026	2701.17	Mikroschalter	microinterrupteur	Micro-switch	
027	2701.18	Druckschlauch m. Raccord 2x4 L=120	tuyau de pression a. raccord 2x4 L=120	Pressure hose w. connector 2x4 L=120	
028	2403.17	Kunststoffunterlage	support plastique	Plain washer	
029	2401.33	Feder zu Thermosicherung	ressort de compression	Pressure spring	
030	2401.39	Schraube TCB M6x30 UNI 7687	vis TCB M6x30 UNI 7687	Screw TCB M6x30 UNI 7687	
031	2403.13	Aluminium-Ring	anneau an aluminium	Spacer	
032	2701.20	Schutz Klemmfeder	protection ressort de blocage	Protector spring clip	
033	2393.16	Flachstecker	fiche plat	Flat plug	
034	2401.53	O-Ring 2106 Silikon	or 2106 silikon	O-ring 2106 Silikon	2
035	2701.21	Schraube TCBC M4x12	vis TCBC M4x12	Screw TCBC M4x12	
036	2701.22	Messinghalterung z. Thermblock	support en laiton	Brass support	1
037	2390.63	O-Ring klein zu Stutzen	o-ring pet. p soutien	O-ring, 2018 silicone	
038	2701.23	Sensor komplett	detecteur compl.	Sensor complete	
039	2401.36	Thermostathalterfeder	ressort de retenue thermostat	Spring thermostat	
040	2401.39	Schraube TCB M6x30 UNI 7687	vis TCB M6x30 UNI 7687	Screw TCB M6x30 UNI 7687	
041	2701.26	Thermostat 170°	thermostat 170°	Thermostat 170°	
042	2503.43	Feder zu Zapfen	ressort de tourillon	Spring for nozzle	5
043	2402.20	Adapter zu Supportventil	adapteur pour soupape support	Adapter for sliding valve	5
044	2402.17	Ventilstift	soupape support	Valve support	5

SOLIS LTD SOLIS-House CH-8152 Glattbrugg E-Mail tec@solis.ch	SOLIS Palazzo TD_Palazzo_Solis_25.03.05	Revision	Page 7 of 20
		C	Barbara Brechbühl Technik/Entwicklung

Pos	Art-Nr.	Artikelbezeichnung Deutsch	Description francais	Description english	Sp set
045	2400.80	O-Ring orm 0080-20 Silikon	or m 0100-15 silicon	O-ring, 80.20	20
046	2402.16	Ventilzapfen	bouchon de valve	Valve nozzle	5
047	2400.77	O-Ring orm 0090-20 Silikon	or m0090-20	O-ring 90-20	20
048	2400.76	O-Ring orm 0050-20 Silikon	or m 0050-20 epdm	O-ring 50-20	20
049	2402.18	Plättchen	plaquette	Plate	5
050	2503.40	Schraube Tspc M5 x 20	vis tcb M5 x 20	Screw TSPC M5 x 20	
051	2503.41	Isolations-Distanzscheibe	rondelle d'ecartement isolante	Insulating spacer	
052	2701.27	Heizungshalter	support de chauffage	Heater support	1
053	2701.28	Kabel mit Thermosicherung	cable avec thermofusible	Cable with thermal fuse	
054	2701.29	Druckschlauch mit Raccord 2.2x4 L=275	tuyau de pression a. raccord 2.2x4 L=275	Pressure hose w. connector 2.2x4 L=275	
055	2701.30	Klixon 120° 230V	klixon 120° 230V	Klixon 120° 230V	
056	2701.31	Schnellverschluss	fermeture rapide	Quick-acting closure	1
057	2503.24	Zugentlastungsbride	bride de detente de traction	Cord grip	
058	2401.48	Anschlusskabel sw L=1500 CH	cable noir CH	Power cord black CH	
058	2504.28	Anschlusskabel sw L=1500 Schuko	cable noir schuko	Power cord black schuko	
059	2701.32	Schlauchklemme D=9.5	tuyau borne D=9.5	Hose clamp D=9.5	

SOLIS LTD SOLIS-House CH-8152 Glattbrugg E-Mail tec@solis.ch	SOLIS Palazzo TD_Palazzo_Solis_25.03.05	Revision	Page 8 of 20
		C	<i>Barbara Brechbühl</i> Technik/Entwicklung

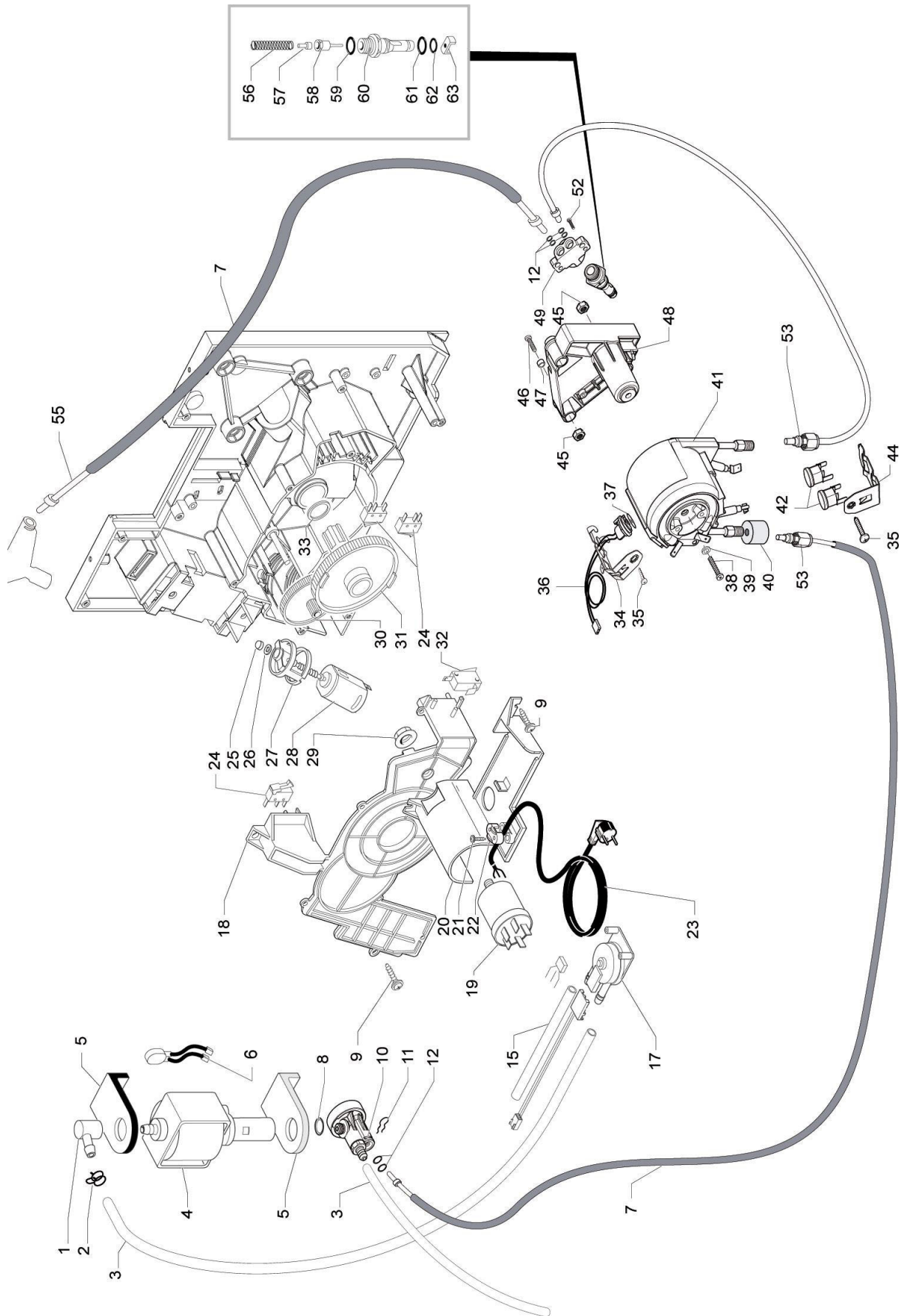

Pos	Art-Nr.	Artikelbezeichnung Deutsch	Description francais	Description english	Sp set
001	2401.22	Gummi Raccord 90°	raccord en gomme 90 degre	Angled rubber connector	
002	2701.32	Schlauchklemme D=9.5	tuyau borne D=9.5	Hose clamp D=9.5	
003	2701.24	Silikon- Schlauch L=230 5x8	tuyau de silicon L=230 5x8	Silicone tube L=230 5x8	
004	2390.92	Pumpe EX5 230V	pompe ex5 230V	Pump EX5 230V	2
005	2503.11	Pumpenaufhängung	suspension de la pompe	Pump support	
006	2701.30	Klixon 120° 230V	klixon 120° 230V	Klixon 120° 230V	
006	2703.07	Klixon 120° C UL 120V	klixon 120° C UL 120V	Klixon 120° C UL 120V	
007	2702.07	Silikon Schlauch sw7,5x9,3x230	tuyau de silicon noir 7,5x9,3x230	Silicone tube 7,5x9,3x230	
008	2391.23	Dichtung zu Sicherheitsventil	joint torique 2031	O-ring, 2031	
009	2502.53	Schraube Tcb 3,5 x 16	vis tcb 3.5x16	Screw, TCB 3.5 x16	
010	2702.08	Überdruck+ kompensations Ventil	soupape de surete	Safety valve	
011	2503.13	Klemmfeder	ressort de blocage	Spring clip	
012	2503.14	O-Ring 2015 silikon PTFE/FDA	joint torique 2015	O-ring, 2015	20
015	2701.25	Silikon- Schlauch L=220 5x10	tuyau de silicon L=220 10x8	Silicone tube L=220 10x8	
017	2701.13	Flowmeter kompl.	turbine compl.	Flowmeter complete	
018	2701.10	Getriebedeckel grau	couvercle d'engrenage gris	Gear box lid grey	
019	2503.97	Entstörfilter	filtre anti parasite	Noise filter	1
020	2701.11	Flowmetersupport	support de la turbine	Support flowmeter	
021	2502.53	Schraube Tcb 3,5 x 16	vis tcb 3.5x16	Screw, TCB 3.5 x16	
022	2503.24	Zugentlastungsbride	bride de detente de traction	Cord grip	
023	2401.48	Anschlusskabel sw L=1500 CH	cable noir CH	Power cord black CH	
023	2504.28	Anschlusskabel sw L=1500 Schuko	cable noir schuko	Power cord black schuko	
024	2401.58	Mikroschalter Getriebe Xch5-81	interrupteur miniature command	Micro-switch	4
025	2401.55	Lager	depot	Porous bearing for geared motor	
026	2401.54	Unterlagscheibe D 5,5	rondelle d 5,5	Bakelite washer for geared motor	
027	2401.51	Schwingungsdämpfer	etouffeur	Rubber bearing for geared motor	
028	2701.39	Getriebemotor kompl.	moteur compl.	motor kompl.	
029	2503.98	Mutter zu Entstörfilter	écrou pour filtre anti parasite	Nut for noise filter	
030	2701.19	Schneckenrad ZE weiss	roue helicoidale	Worm gear wheel	
031	2701.14	Antriebsrad	roue d'entrainement	Drive wheel	
032	2701.17	Mikroschalter	microinterrupteur	Micro-switch	
033	2403.17	Kunststoffunterlage	support plastique	Plain washer	
034	2701.89	Sensorhalter	support de la sensor	Sensor support	
035	2702.20	Schraube TCB PZ/TT 4x8 UNI 8112	vis TCB PZ/TT 4x8 UNI 8112	Screw TCB PZ/TT 4x8 UNI 8112	
036	2702.17	Sensor	dedecteur	Sensor	
037	2702.27	Isolationsscheibe Keratherm	disque d'isolement Keratherm	insulating washer Keratherm	
038	2702.22	Schraube TCB M5x20 UNI 7687 ZNP	vis TCB M5x20 UNI 7687 ZNP	Screw TCB M5x20 UNI 7687 ZNP	
039	2702.23	Zahnscheibe D=5.2 mm rostfrei	disque dentée D=5.2 mm rostfrei	toothed washer D=5.2 mm rostfrei	
040	2701.20	Schutz Klemmfeder	protection ressort de blocage	Protector spring clip	
041	2702.34	Thermoblock 230V	chauffe-eau 230V	Water heater 230V	2
041	2703.12	Thermoblock 120V	chauffe-eau 120V	Water heater 120V	
042	2702.28	Thermostat 175°	thermostat 175°	Thermostat 175°	
044	2702.30	Thermostat Haltefeder	ressort de retenue thermostat	Spring thermostat	

SOLIS LTD SOLIS-House CH-8152 Glattbrugg E-Mail tec@solis.ch	SOLIS Palazzo TD_Palazzo_Solis_25.03.05	Revision	Page 10 of 20
		C	Barbara Brechbühl Technik/Entwicklung

Pos	Art-Nr.	Artikelbezeichnung Deutsch	Description francais	Description english	Sp set
045	2702.26	Mutter M5 UNI 5587-68	écrou M5 UNI 5587-68	Nut M5 UNI 5587-68	
046	2702.29	Schraube TSP M5.0x30 UNI 7688 ZNP	vis TSP M5.0x30 UNI 7688 ZNP	Screw TSP M5.0x30 UNI 7688 ZNP	
047	2503.41	Isolations-Distanzscheibe	rondelle d'ecartement isolante	Insulating spacer	
048	2702.33	Heizungssupport	support de chauffage	Heater support	
049	2702.32	Messing Raccord kompl.	raccord en laiton compl.	Brass Raccord compl.	
052	2702.18	Schraube HI-LO 3,5x15	vis HI-LO 3,5x15	Screw HI-LO 3,5x15	
053	2702.11	Druckschlauch mit Raccord L=250mm	tuyau de pression a. raccord L=250mm	Pressure hose w.connector L=250mm	
055	2701.90	Druckschlauch mit Raccord L=330mm	tuyau de pression à raccord L=330mm	Pressure hose w. connector L=330mm	
056	2503.43	Feder zu Zapfen	ressort de tourillon	Spring for nozzle	5
057	2402.20	Adapter zu Supportventil	adapteur pour soupape support	Adapter for sliding valve	5
058	2402.17	Ventilstift	soupape support	Valve support	5
059	2400.80	O-Ring orm 0080-20 Silikon	or m 0100-15 silicon	O-ring, 80.20	20
060	2402.16	Ventilzapfen	bouchon de valve	Valve nozzle	5
061	2400.77	O-Ring orm 0090-20 Silikon	or m0090-20	O-ring 90-20	20
062	2400.76	O-Ring orm 0050-20 Silikon	or m 0050-20 epdm	O-ring 50-20	20
063	2402.18	Plättchen	plaquette	Plate	5

SOLIS LTD SOLIS-House CH-8152 Glattbrugg E-Mail tec@solis.ch	SOLIS Palazzo TD_Palazzo_Solis_25.03.05	Revision	Page 11 of 20
		C	<i>Barbara Brechbühl</i> Technik/Entwicklung

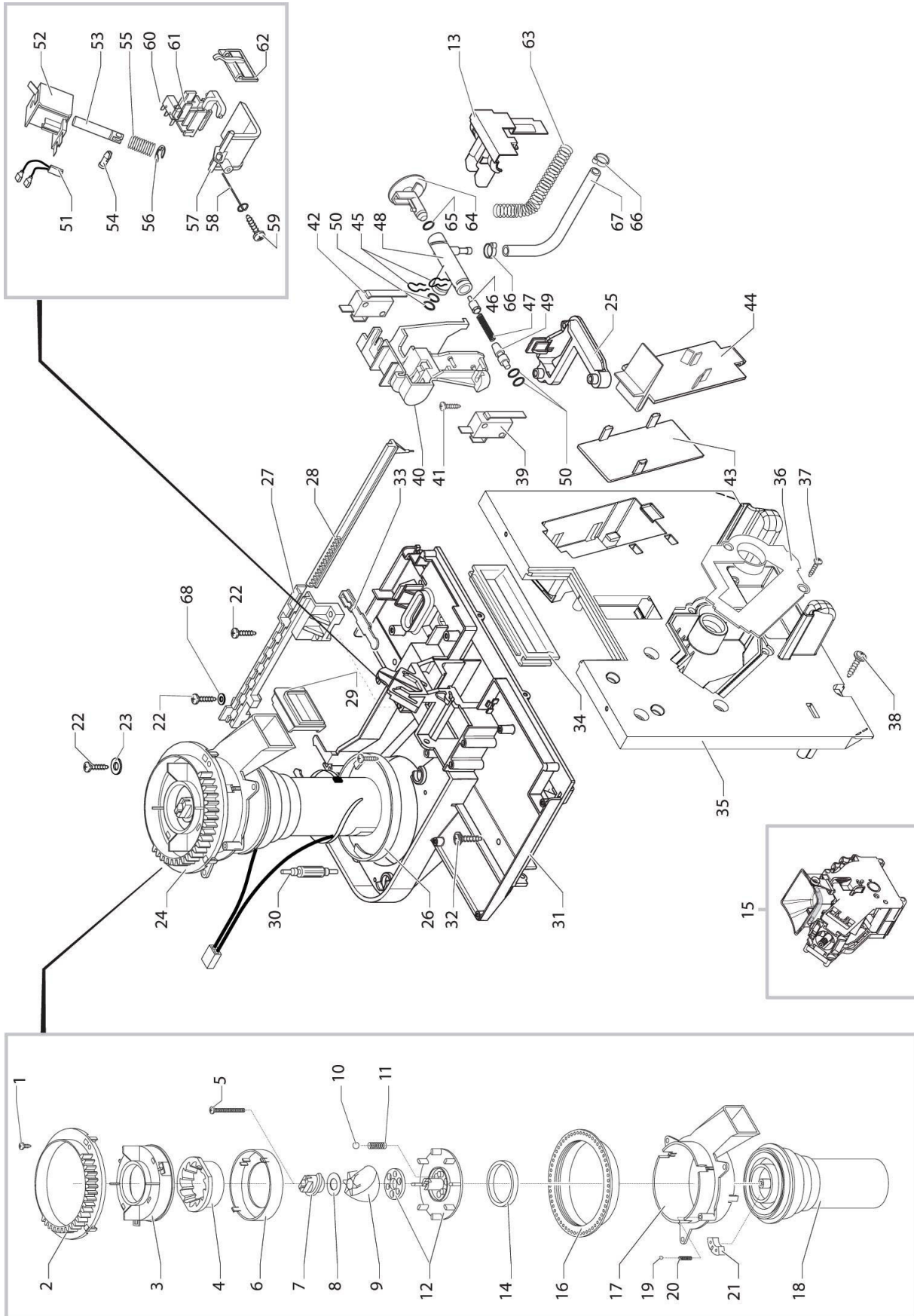

Pos	Art-Nr.	Artikelbezeichnung Deutsch	Description francais	Description english	Sp set
001	2502.71	Schraube TCB 2,9x6,4 DIN 7981	vis TCB 2,9x6,4 DIN 7981	Screw TCB 2,9x6,4 DIN 7981	
002	2503.73	Regulerring	regulation	Regulator	
003	2401.65	Mahlringaufnahme	reception du disque de mouture	Grinding ring retainer	
005	2401.70	Schraube 3,5 x 48	vis 3,5x48	Screw 3.5 x 48	
006	2401.67	Mahlringabdeckung	recouvrement du disque de mout	Grinding ring cover	
007	2503.74	Schnecke für Kegel	vis de roue conique	Endless screw for cone	
008	2401.29	Pass-Scheibe 10 x 16 x 0,2	disque 10 x 16 x 0.2	Plain washer, 10 x 16 x 0.2	
009	2401.66	Mahlring/Mahlkegel komplett	disque de mouture/disque compl	Grinding ring/ cone compl.	2
010	2402.60	Stahlkugel D 5,5 Inox	boule D= 5.5 inox	Steel ball, D=5.5	
011	2402.54	Feder zu Trägerscheibe	ressort p. helice	Spring for support washer	
012	2403.14	Trägerscheibe mit Stahlring	disque portante	Support washer with steel ring	
013	2701.33	Abdeckung Dampfahh	couverture vapeur robinet	Cover steam tap	
014	2402.55	Filzring	rondelle	Felt washer	
015	2701.34	Zentraleinheit komplett grau	unite centrale compl. gris	Central unit complete grey	
016	2401.72	Verstellring	rondelle	Adjusting ring	
017	2701.35	Mühlensupport	support moteur moulin	Grinder motor support	
018	2702.05	Mahlwerksmotor kompl. 230V Palazzo	moteur moulin 230V	Grinder motor compl. 230V	1
019	2402.64	Stahlkugel D 3.2 Inox	boule	Ball 3.2 Inox	
020	2402.63	Feder zu Kugel D=3.2	ressort p. helice D=3.2	Spring for steel ball, D=3.2	
021	2403.15	Dämpfungsgummi Mahlwerk	gomme amortissement p. moulin	Rubber vibration absorber f. grinder	
022	2701.36	Schraube Panelvit TCB 3.5x18 DIN 7505	vis Panelvit TCB 3.5x18 DIN 7505	Screw Panelvit TCB 3.5x18 DIN7505	
023	2701.37	U-Scheibe 4.3x16 UNI 6592	anneau 4.3x16 UNI 6592	Washer 4.3x16 UNI 6592	
024	2701.38	Mahlwerk komplett 230V	mecanisme du moulin compl. 230V	Grinder complete 230V	1
025	2701.40	Distanzsupport	distance support	Spacersupport	
026	2503.51	Verstärkungsring zu Mahlwerk	rondelle de renfort de mecan.	Reinforcing ring for grinder	
027	2701.41	Halter Kaffeemengenregulierung	regulation debit	Coffeevolume regulating	2
028	2701.42	Schlitten zu Kaffeemengenreg.	luge pour regulation debit	Slide coffeevolume regulation	2
029	2701.43	Dichtung	joint	Seal	
030	2503.54	Antivibration für Mahlwerk	dispositif antri. du mecan.	Anti-vibration arrangement f. grinder	
031	2701.44	Mühlensupport	support moulin	Grinder support	1
032	2502.53	Schraube Tcb 3,5 x 16	vis tcb 3.5x16	Screw, TCB 3.5 x16	
033	2503.56	Dosierverstellhebel	levier de dosage réglable	Proportioning adjustment lever	
034	2701.45	Abdeckung	couverture	Cover	
035	2701.46	Montageplatte	plaque de montage	Mounting plate	1
036	2701.47	Deckel	couverture	Cover	
037	2502.16	Schraube 3.5x9.5	vis 3.5x9.5	Screw, 3.5x9.5	
038	2502.53	Schraube Tcb 3,5 x 16	vis tcb 3.5x16	Screw, TCB 3.5 x16	
039	2701.48	Mikroschalter Türe	microinterrupteur port	Micro-switch door	2
040	2701.49	Hahnsupport	support du robinet	Tap support	
041	2701.50	Schraube TCB 3.5x22 DIN 7981	vis TCB 3.5x22 DIN 7981	Screw TCB 3.5x22 DIN 7981	
042	2701.51	Mikroschalter	microinterrupteur	Micro-switch	2
043	2701.52	Innendeckel	couverture interne	Cover interior	
044	2701.53	Aussendeckel	couverture externe	Cover exterior	

SOLIS LTD SOLIS-House CH-8152 Glattbrugg E-Mail tec@solis.ch	SOLIS Palazzo TD_Palazzo_Solis_25.03.05	Revision	Page 13 of 20
		C	Barbara Brechbühl Technik/Entwicklung

Pos	Art-Nr.	Artikelbezeichnung Deutsch	Description francais	Description english	Sp set
045	2503.13	Klemmfeder	ressort de blocage	Spring clip	
046	2400.97	Supportventil	soupape	Valve complete	5
047	2701.64	Feder	ressort	Spring	
048	2701.54	Hahnenkörper	corps robinet vapeur	Steam tap body	5
049	2701.55	Verschlusszapfen Hahnen	pivot de cloture	Pivot bolt	
050	2503.14	O-Ring 2015 silikon PTFE/FDA	joint torique 2015	O-ring, 2015	
051	2701.56	Thermoschutz zu Dosierspule 230V	thermo protection 230V	Thermal protection 230V	
052	2701.57	Dosierspule 230V	bobine d'induction 230V	Dosing coil 230V	1
053	2401.91	Anker	ancre	Anchor	
054	2401.97	Bolzen zu Anker	goujon pour ancre	Pin for proportioning flap	
055	2401.89	Feder zu Dosierer	ressort p. dosateur	Spring for proportioning electrom.	
056	2401.90	Scheibe 7 Uni 7434	disque 7 uni 7434	Absorption ring	
057	2401.98	Klappe	trappe	Proportioning flap, grey	
058	2401.96	Abstreifer	devetisseur	Stripper	
059	2502.72	Schraube TCB 3x12	vis TCB 3x12	Screw TCB 3 x12	
060	2401.92	Mikroschalter Xch 5-81	interrupteur xch 5-81	Proportioning micro-switch	2
061	2401.93	Verstellteil	mecanisme de changement	Support for proportioning micro-switch	
062	2401.94	Schaltstück	distributeur	Contactactor	
063	2701.59	Feder D=7.5 mm	ressort D=7.5 mm	Spring D=7.5 mm	
064	2701.60	Heisswasserspindel	broche d'eau chaude	Hot water spindle	
065	2701.61	O-Ring D=4.48x1.90 EPDM	joint D=4.48x1.90 EPDM	O-ring D=4.48x1.90 EPDM	
066	2701.62	Schlauchbride Oetiker	tuyau borne	Hose clamp	5
067	2701.63	Schlauch 3x7 L=240 Silikon	tuyau 3x7 L=240 silicon	Hose 3x7 L=240 silicon	2
068	2700.92	U-Scheibe D=3.3x9	anneau D=3.3x9	Washer D=3.3x9	

SOLIS LTD SOLIS-House CH-8152 Glattbrugg E-Mail tec@solis.ch	SOLIS Palazzo TD_Palazzo_Solis_25.03.05	Revision	Page 14 of 20
		C	Barbara Brechbühl Technik/Entwicklung

Pos	Art-Nr.	Artikelbezeichnung Deutsch	Description francais	Description english	Sp set
001	2402.24	Schraubmutter für ZE	ecrou pour unite centrale	Nut for central unit	5
002	2402.25	O-Ring R5 Epdm	or r5 epdm	O-ring R5	5
003	2701.65	Kolben grau	piston	Piston	1
004	2402.28	O-Ring orm 0320-40 Epdm	or orm 0320-40 epdm	O-ring 0320-40 Epdm	5
005	2701.66	Verschluss grau	fermeture	Closure	
006	2701.88	Einsatz für Sieb Brühgruppe	insertion pour formation tami super.	Insertion for upper sieve group	5
007	2402.32	Ventilkörper	corps de soupape	Valve body	5
008	2402.33	O-Ring 2025 Epdm	or 2025 epdm	O-ring 2025	5
009	2701.68	Platte vorne + hinten	plaque arriere + deriere	Panel rear + front	
010	2701.69	Kugel D=4.5 BN 1353 Inox	boule D=4.5 BN 1353 Inox	Ball D=4.5 BN 1353 Inox	
011	2701.70	O-Ring 0060-15 EPDM	joint 0060-15 EPDM	O-ring 0060-15 EPDM	
012	2701.71	Schlauch 3.5x6 Silikon, L= 75 mm	tuyau 3.5x6 silikon	Hose 3.5x6 silikon	5
013	2402.23	Schraube TCB 3x10 DIN	vis tcb 3.0x10 din	Screw TCB 3 x 10	
014	2701.72	Auslauf-Flansch	bride de demarrage	Inlet flange	
015	2701.73	Feder	ressort	Spring	
016	2503.80	Sieb oben mit Schraube D=35,8	tamis super. avec vis d=35.8	Sieve, upper, with screw D=35.8	2
017	2701.74	Kurbelwelle	abre coude	Crankshaft	
018	2403.26	Kaffeekammer	chambre	Coffee compartment	
019	2402.41	Gleiter	glisseur	Slide	
020	2701.75	Kupplung Kaffeeauslauf	couplage d'ecoulement de café	Coupling coffee outlet	2
025	2701.79	O-Ring 0090-25 EPDM	joint 0090-25 EPDM	O-ring 0090-25 EPDM	
026	2402.39	Steuerhebel	cevrier de commande	Control lever	
027	2402.43	Kratzer	grattoir	Stripper	
028	2401.77	Feder	ressort	Spring	
029	2401.61	Schraube 2,9 x 19	vis 2.9x19	Screw, TCB 2.9 x 19	
030	2701.80	Trichter zu ZE-Press grau	cone pour zd compresseur	Funnel central unit press	
031	2701.81	Kupplungssupport	support de couplage	Support coupling	
032	2700.31	Schraube TBC 2.9x9.5 DIN 7981 Inox	vis TBC 2.9x9.5 DIN 7981 Inox	Screw TBC 2.9x9.5 DIN 7981 Inox	
033	2701.82	Feder	ressort	Spring	
035	2502.41	Blechschaube TCB 3.5x19	vis TCB 3.5x19	Screw TCB 3.5x19	
036	2701.34	Zentraleinheit komplett grau	unite centrale compl. gris	Central unit complete grey	1
037	2503.81	Schraube M3x14	vis M3x14	Screw M3x14	
038	2503.82	Sieb D=35,8	tamis d=35.8	Sieve D=35.8	
039	2403.27	Stössel komplett mit Sieb	pilon compl.	Tappet, complete with sieve	

SOLIS LTD SOLIS-House CH-8152 Glattbrugg E-Mail tec@solis.ch	SOLIS Palazzo TD_Palazzo_Solis_25.03.05	Revision	Page 16 of 20
		C	Barbara Brechbühl Technik/Entwicklung

Testmodus, Solis Palazzo

Testmodus

1. Maschine **AUS**
2. Kaffee und Dampfaste halten
3. Maschine **EIN**

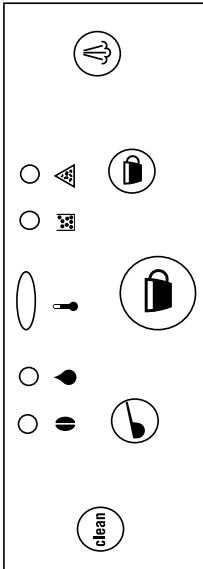

	Reinigung		Einwurf		Kaffee		Espresso		Dampf		Hahnen		Werte der Anzeige	
	Taste	LED	Taste	LED	Taste	LED	Taste	LED	Taste	LED	zu	offen	LED	LED
X = Taste drücken O = LED leuchtet														
clean														
Analoge Anzeigen:														
Lampentest	X	O	X	O	O	O	O	O	O	O	O	O	O	O
Thermoblocktemperatur	X	>= 98°C		<= 94°C		96°C		95°C		97°C				
Komponententest:														
Pumpe			X						X					
Heizung	X		X								X			
Kaffeedosierer									X					
Brühgruppe auf			X								X			
Microschalter Brühgruppe in Arbeitsstellung				O										
Brühgruppe ab							X							
Microschalter Brühgruppe in Ruhestellung							O							
Mühle					X						X			
Microschalter Kaffeedosierer voll						O								
Microschalter Brühinheit									O					
Microschalter Türe		O												
Reed Wassertank										O				
Microschalter Satzbehälter											O			
Flowmeter (Luft durchs Flowmeter blasen. Schlauch zur Pumpe lösen)													O	
Binäre Anzeigen:														
Werte Binärcode					4	2	1	128	64	32	16	8		
Mahlwerkstrom					X	O	O	O	O	O	O	O	O	122 - 132 Dosierer voll 140 - 150 Leerlauf ca. 170 Kaffee mahlen > 200 Mühle blockiert
Wasserfluss pro sek.			X			O	X	O	O	O	O	O	O	ca. 40 - 50
Thermoblocktemperatur	X					O	O	O	O	O	O	O	O	

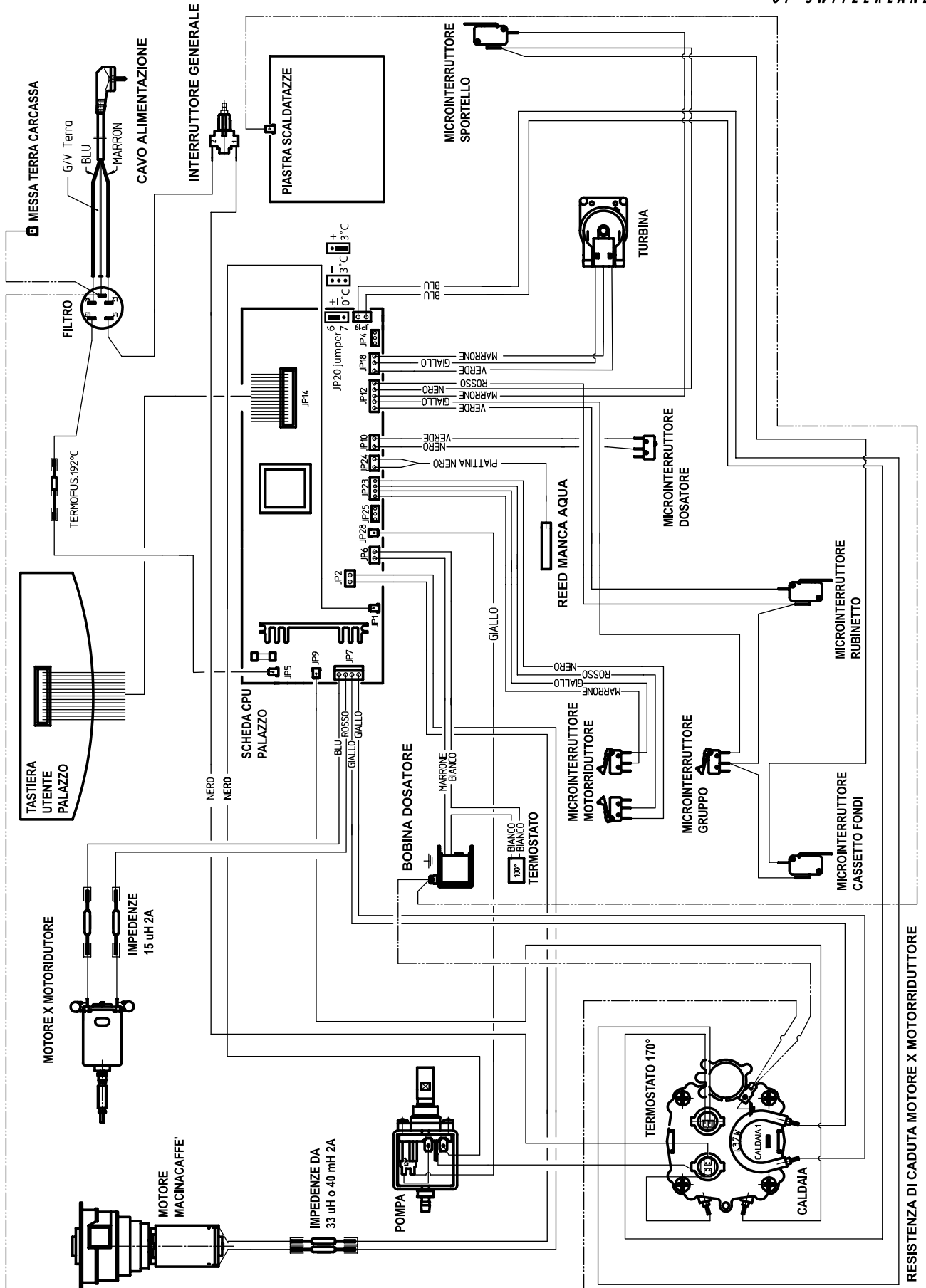

RESISTENZA DI CADUTA MOTORE X MOTORIDUTTORE

Italiano	Deutsch	English	Francais
Termofusibile	Temperatur-sicherung	Thermal protection	Contrôle de température
Termostato	Sicherheits-thermostat	Safety protection	Contrôle de Sécurité
Resistenza di caduta x motore motorriduttore	Vorwiderstand Motor	Preresister gear motor	Résistance pour moteur
Motore motorriduttore	Getriebemotor	Gear motor	Moteur d'engrenage
Impedenze	Drossel	Impedance coil	Bobine d'impédance
Macinacaffè	Mühle	Grinder	Moulin
Bobina dosatore	Spule Dosierer	Coil for doser	Commande
Scheda cpu	Steuerung	PC- board	carte imprime de commande
Caldaia	Boiler	Boiler	Corps de chauffe
Turbina	Turbine	Flowmeter	Debitmetre
Messa terra carcassa	Erde Gehäuse	GND housing	Terre boitier
Microinterruttore	Mikroschalter	Micro switch	Micro interrupteur
Dosatore	Kaffeedosierer	Doser coffee	Dosage du café
Rubinetto	Dampf	Steam tap	Vapeur
Gruppo	Brüheinheit	Brewing group	Unité centrale
Motorriduttore	Getriebe	Gear box	Engrenage
Cassetto fondi	Satzbehälter	Waste bucket	Tiroir marc de café
Sportello	Fronttüre	Front door	Porte
Interruttore generale	Hauptschalter	Main switch	Interrupteur principale
Filtro	Netzfilter	Noise filter	Bobine de reseau
Reed manca aqua	Reed Wassermangel	Reed fresh water tank	Reed contrôle niveau d'eau
Pompa	Pumpe	Pump	Pompe
Piastra scaldatazze	Tassenablage	Feuille p. tasses	Cup tray
Tastiera utente	Bedienprint	Print keyboard	Print clavier
Cavo alimentazione	Netzkabel	Main plug	Câble d'alimentation
G / V Terra	Gelb / Grün Erde	Yellow / Green GND	Jaune / Vert Terre
Nero	Schwarz	Black	Noir
Blu	Blau	Blue	Bleu
Bianco	Weiss	White	Blanc
Marrone	Braun	Brown	Marron
Rosso	Rot	Red	Rouge
Verde	Grün	Green	Vert
Giallo	Gelb	Yellow	Jaune